

PRORIL

50Hz

Designed for light weight, excellent performance, low energy consumption, and easy maintenance, PRORIL submersible handy pumps serve a wide range of pumping applications on utility, construction, industrial, and municipal job sites.

Handy and Residue Pump **SMART 1500**

Handy Pump



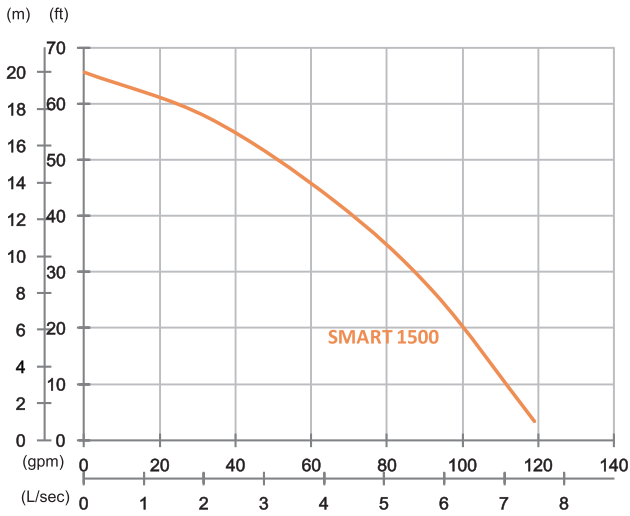

SMART 1500

OUTPUT	1.5 kW (2 HP)
OUTLET	2" (50 mm)
SOLID PASSAGE	9 mm
Weight	24 kg
HEAD	Rated: 13 m Max: 20 m
FLOW	Rated: 4.2 L/s Max: 7.5 L/s

Pump Type		Electric Submersible Pumps
Motor	Phase	1-Phase, 3-Phase
	Type	Induction Motor
	Poles	2 Pole (2850 rpm)
	Insulation	Class F
	Protector	Circle Thermal Protector
	Starter	1-Phase • Capacitor-Run, 3-Phase • D.O.L
Lubricant		Food Grade (ISO VG32)
Specs.	Impeller Type	Opened
	Shaft Seal	Double Mechanical Seal
		Silicon Carbide VS Ceramic/Carbon
	Bearings	C3 Shielded ball bearings
	Cable	H07RN-F
10 m or longer upon request		
Materials	Pump Casing	Gray Iron
	Impeller	Gray Iron
	Motor Frame	Stainless Steel
	Motor Shaft	Stainless Steel
	Outer Case	Stainless Steel
	Strainer	Stainless Steel
Max. Liquid Temperature		40°C (104°F)
Max. Submersion Depth		20 m (66 ft)
pH Range		pH 5 - pH 8

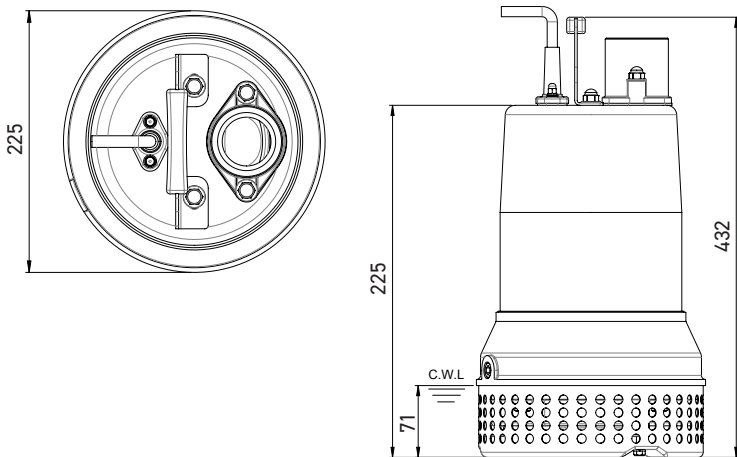

unit : mm
C.W.L : Continuous running water level